

# Implementation of VANET based Accident Detection System

Mr. Rakesh K R\*, Ojashwini R N\*\* and Greeshma N D\*\*\*

\*Assistant Professor, Dept. of Telecommunication Engineering, RVCE, Bengaluru  
Email: rakeshkr@rvce.edu.in

\*\*\_\*\*\*Student, Dept. of Telecommunication Engineering, RVCE, Bengaluru  
Email: ojashwini21@gmail.com, greeshmandrai@gmail.com

**Abstract:** The sudden increase in vehicular traffic and congestion on the highways become threatening to safety and efficient movement of traffic. As a result there is an ascending rate of accidents, which leads to exploiting new technologies e.g. wireless sensor network has become most reliable, safety and secured technique of these saddening and reprehensible statistics. This has motivated to propose a model and comprehensive approach to utilize Wireless Sensor Networks for vehicular networks. Vehicular AdHoc Network's are the standard phenomenon to provide safety and for secured applications. It plays an important role as a part of intelligent transport system. It is a self-organizing AdHoc network where sensor nodes are deployed in large number. It increases safety and comfort for vehicles by making an efficient use of wireless communication between stationary nodes and the nodes under motion. In the proposed model, pressure sensors deployed in the vehicle senses the pressure continuously. On occurrence of accidents, the pressure increases above the threshold and informs the vehicles in the vicinity by the buzzer. Also it sends a notification to the specified receivers and base stations.

**Keywords:** VANET, roadside unit, base station, piezo sensor, power supply.

## Introduction

The sheer volume of road traffic results in traffic jams on highways and also increases accident rate. If the information of current traffic is sent to the vehicle then traffic can be easily managed by analysing it and routing the vehicles accordingly. Few models continuously track the vehicles but were limited by number of objects [1]. Some models were designed for applications where accurate tracking is done even in absence of good lighting conditions. Algorithm based on frame differencing and dynamic template matching was used [2]. Several models were built based on the use of object representations and contour evolution which required object detection at some point [3]. Also surveillance systems were built to monitor and track people which employed a combination of shape analysis and tracking to locate [4].

Using frame differencing and template matching object can be tracked in which the difference in frames of moving object is considered. It can be used to track an object of interest from a group of moving and detected object. Such systems use object Template matching algorithm [6]. For tracking multiple objects in a single frame the centroid of objects is the main focus. But the information collected in such systems will be insufficient to enhance localization. It requires addition of some structure information [7]. A combination of sum of squared differences (SSD) and colour based mean shift (MS) tracker will give better performance in tracking. As colour is taken to consideration performance of tracker will be hindered if object is partially occluded [8].

One popular VANET routing protocol is Ad-hoc On Demand Vector Routing (AODV) which uses a demand-driven route establishment procedure [9]. A limitation of this approach is that it creates flooding type of situation within entire network. To solve this problem Active Route timeout is established using E-AODV. It utilizes hello interval and Active Route timeouts parameters to choose the best routing route. E-AODV has better Routing results and QoS as compared to AODV protocol [10]. Another approach uses routes, that are stored in cache and it is expected that source will have complete knowledge of hop-by-hop route to the destination [11]. Another approach is border node concept. It is based on stop and carry mechanism [12].

In the proposed model the vehicles form the nodes which are mobile in state. This leads to a self-organisable mobile network. In VANET two kinds of communication is possible. First one is vehicle to vehicle communication which does not involve any infrastructure support. The latter one is the communication connecting vehicles with fixed infrastructures called road side units (RSU).

## System Architecture

In this section the structure of the system is explained. It consists of piezo sensor, monostable multivibrator, power supply unit, IR transmitter and receiver, RF transmitter and receiver, LCD 16x2, microcontroller, buffer, driver and relay and buzzer.

Hardware module with piezo sensor is deployed in vehicle which forms the vehicle nodes. Here piezo sensor senses the pressure and information about increased pressure occurred due to accident is delivered within the vehicle, through multivibrator and interfacing unit, which in response turn on buzzer and signal is transmitted to roadside unit through IR transmitter. Figure 2 and Fig 3 shows the transmitter and receiver units of proposed methodology respectively.

The signal received at IR receiver is transmitted to base station via RF transmitter indicating that accident is detected in that particular area. Broad casting region consists of IR Transmitter and IR Receiver unit. This region is divided into two areas, namely: Area A and Area B. Fig 4 shows the block diagram of roadside unit.

IR receiver receives the signal and activates a particular relay, the relay output is connected to particular pins of microcontroller to which a code is dumped already and when particular pin is given with an input it displays that particular area name. Fig 5 shows the block diagram of base station of proposed methodology. Fig 6 shows the block diagram of DC power supply unit.

**Piezo Sensor**

When an accident is detected, the stress or pressure created due to collision between the vehicles becomes an input to the piezoelectric material. A potential difference with magnitude equal to the exerted force is produced across piezoelectric transducer.

**Monostable Multivibrator**

It is a single mode state multivibrator where once the input is given to the multivibrator from the piezo sensor, it keeps on triggering the circuit till the input becomes less than its threshold i.e. pressure due to collision will get decrease which states that the vehicles under accident get separated.

**Power Supply**

The power supply architecture works with 12V and 5V. It consists of four blocks, namely: transformer, rectifier, filter and regulator. In the model step down transformer is used to step down the input voltage 230 V AC supply to 12-0-12 AC voltage. Rectifier converts AC into DC but along with DC voltage some portions of AC components are get added which can be filtered in the filter stage. In order to get exact voltage for the circuit operations regulators are used.

**Buffer, Driver and Relays**

Buffers consists of five input signals. It helps in enhancing current and interfacing. The output from buffer is passed to the signal diodes which helps to reduce the back e.m.f, produced due to load and then passed to the driver circuit. The relay is switched by taking input from the driver circuit which involves in various actions according to the requirements in the circuit.

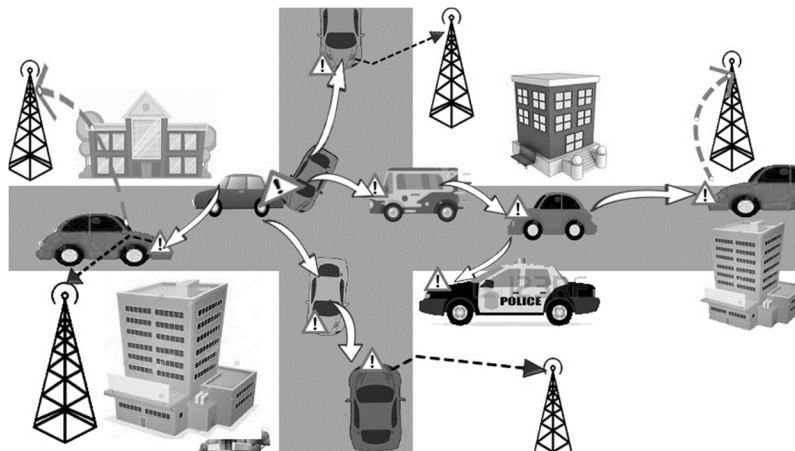

Figure 1: Exchange of information using VANET

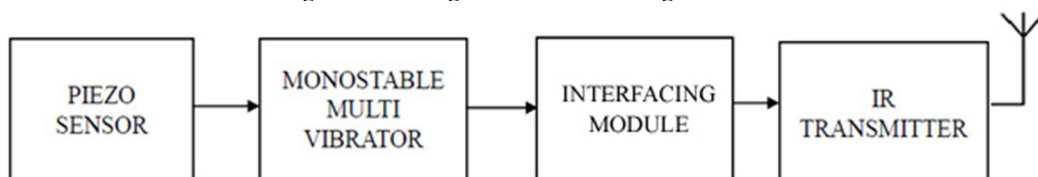

Figure 2: Block diagram of transmitter unit of proposed methodology

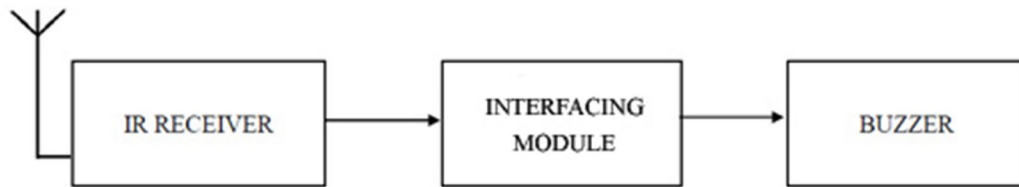

Figure 3: Block diagram of receiver unit of proposed methodology

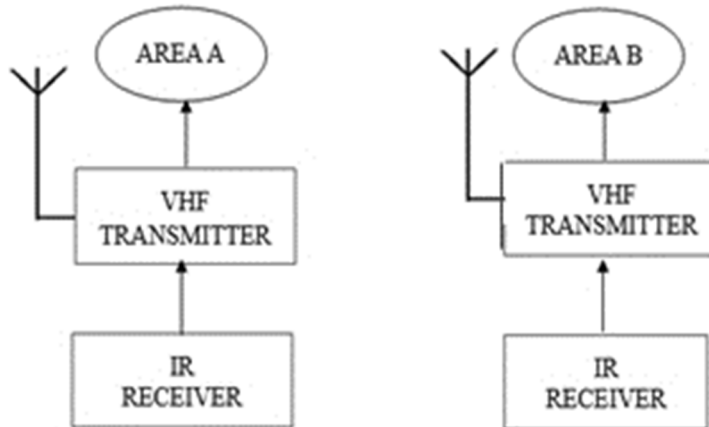

Figure 4: Block diagram of roadside unit

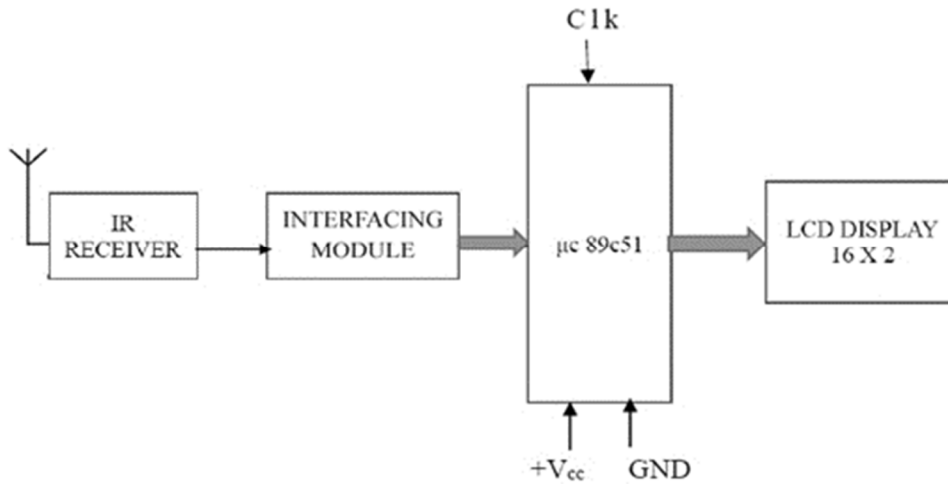

Figure 5: Block diagram of base station of proposed methodology

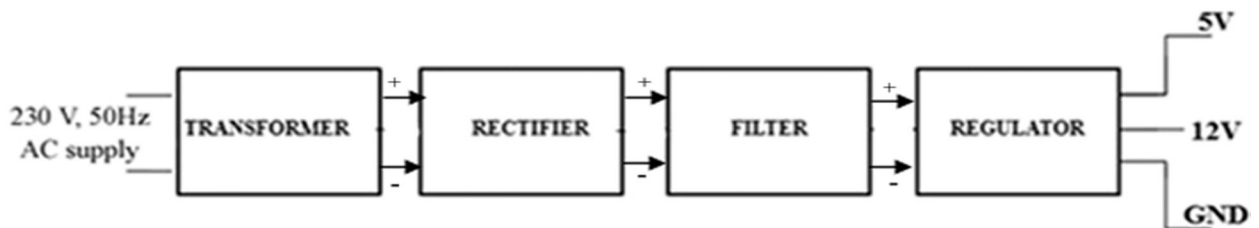

Figure 6: Block diagram of DC power supply unit

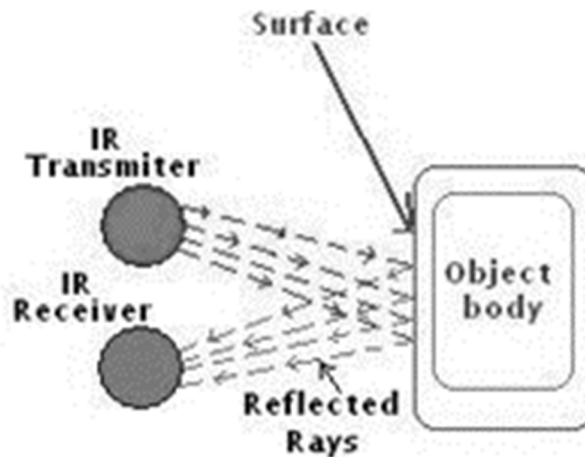

Figure 7: Working of IR transmitter and receiver

### IR Transmitter and Receiver

The signal gets broadcasted through the IR transmitter and is received by the IR Receiver. IR Transmitter 20 pin DIL packaged IC has integrated all the necessary stages to transmit the IR pulse beams to the receiver. The frequency to transmit can be adjusted. It needs outer components to provide oscillations to meet transmitter circuit needs. This frequency is used by the IC as a reference frequency to oscillate. The IC can be used in two modes: Flash Mode, Carrier Mode.

The 'packets' of infra-red light transmitted from the IR Transmitter of user remote control are received on a sensor module which is sensitive to infra-red light. This signal in optical form is converted back into electrical pulses by a receiver and an associated detector. The electrical pulse is fed to driver circuit, which supplies trigger pulse to Schmitt Trigger circuit.

It consists of IR Receiver Eye, a module encapsulated with Photo Transistor whose semiconductor junction is mounted beneath an optical lens. It is normally used in its open base configuration. It acts as a light-to-voltage converter. The base is open; the value of the reverse current across collector and emitter will depend on the amount of illumination on the base face. In dark conditions it is near zero and under bright light it is tens or hundreds of mA resulting in the display of the particular region.

### RF Transmitter and Receiver

The signal gets broadcasted from the transmitter. It is amplified through transistors and passed to the oscillator which helps to get higher frequencies for transmission of longer distance. It is then passed to the tank circuit where isolation and storage of information will take place with the help of RC circuit and once the signal gets processed in these stages it is broadcasted through antenna. The RF receiver receives the broadcasted signal which is again amplified and involved in stabilization process. It is then passed to the buffer, driver and relay circuit.

### Buzzer

It generally comprises of an electromagnetic or a piezoelectric element. In the accident detection system the piezoelectric buzzer is used as an auditory alert.

### Microcontroller

The microcontroller used is 89C51. It is a low-power, high-performance microcontroller with flash memory and it is multiple times programmable.

### LCD Module

LCD (Liquid Crystal Display) with an IC base of 40 pins. When an accident detected, the information about the area is passed to the following vehicles and the base stations according to its requirements and message is displayed in LCD.

### System Design

The implementation will takes place according to the system architecture and it is explained with procedure in this section. Two regions are considered for detection in broadcasting region, namely: Area A and Area B.

1. The two regions are connected to the socket distance of some feet.
2. The system architecture unit should be placed in the centre of all the two areas and should be connected to the socket.

3. The vehicles are moving either in area A or area B, i.e. accident detected in any one of the region.
4. As soon as the other vehicle reaches Area A, the IR transmitted by vehicle unit is received by IR receiver of Area A. The particular code for channel is then sent by IR transmitter to system architecture, then interfaced to microcontroller by a set of buffer circuit, driver stage, and relay switching network and to the parallel port.
5. The LCD present in Microcontroller stage should display the name of area i.e. Area A, and thus the user will come to know that vehicle is in Area A.
6. The vehicle should be move near area B, as soon as it reaches Area B, the message displayed on the LCD will be Area B.

The hex file obtained from the Keil Micro Vision software is dumped to microcontroller using Flash magic software. Fig 8 shows the flow of control during execution.

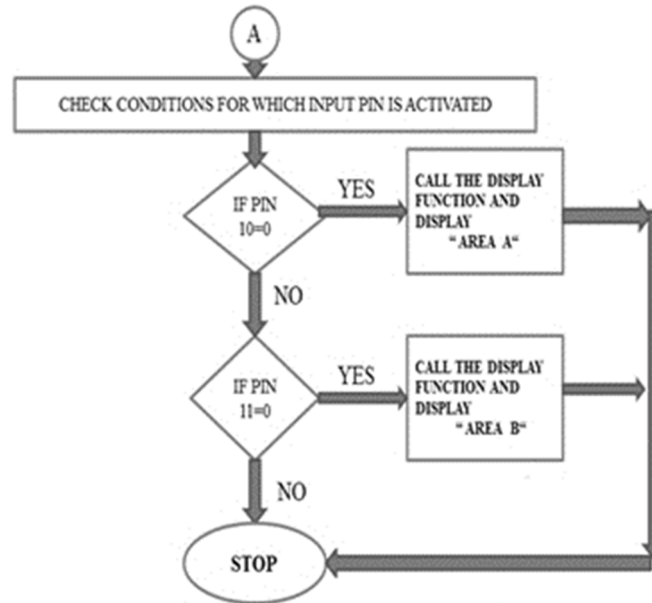

Figure 8: Flow of control during execution

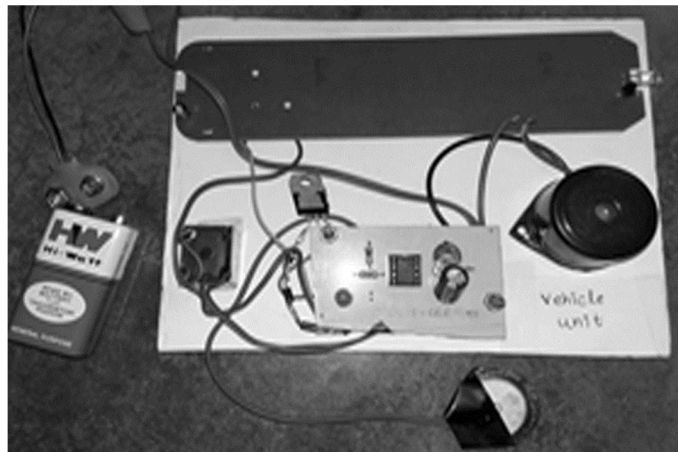

Figure 9: Transmitter unit of proposed methodology

## Results

The accident detection and vehicle tracking is implemented. Fig 9 shows the transmitter unit which is embedded in the vehicle to act as node. Fig 10 shows the base station to which message is sent on accident detection. The system tracks the area in which accident occurs based on the frequency received, which is unique to each area.

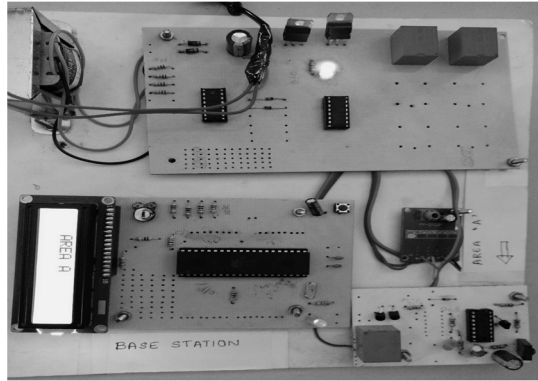

Figure 10: Base station and Area A

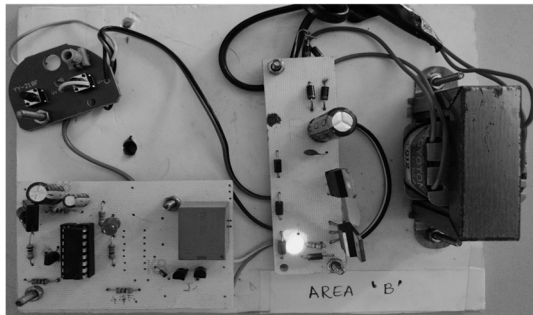

Figure 11: Area B

## Conclusion

The system introduces intelligence in the movement of traffic and increases safety. The vehicle unit must be installed in every vehicle to enable the communication between the nodes. The information of occurrence of the accident is transmitted to the base station which can be hospitals, firefighters etc. Also causes efficient movement of traffic there by reducing the time and fuel wasted due to heavy traffic. The proposed system can be improved by using a PHS system for transmission in the absence of network.

## References

- [1] Jialue Fan, Ying. Wu and Xiaohui. Shen, "What are we Tracking: A Unified Approach of Tracking and Recognition", IEEE Transactions on Image Processing, Vol.22, 2013.
- [2] Anjali. V. Kulkarn and Karan. Gupta, "Implementation of an Automated Single Camera Object Tracking System Using Frame Differencing and Dynamic Template matching", Advances in computer and information Sciences and Engineering, 2008
- [3] Alper Yilmaz, Omar Javed and Mubarak Shah, "Object Tracking: A Survey", ACM Computing Surveys, Vol. 38, No. 4, December 2006.
- [4] Ismail Haritaoglu, David Harwood and Larry S. Davis, "W 4: Who? When? Where? What? A Real Time System for Detecting and Tracking People", IEEE Transaction on Patt. Analy. Mach. Intell, Vol. 22, No. 8, pp. 809-830, 1998.
- [5] G. Mallikarjuna Rao and Dr.Ch.Satyanarayana, "Object Tracking System Using Approximate Median Filter, Kalman Filter and Dynamic Template Matching" ijisa, May 2009.
- [6] N. Prabhakar, V. Vaithyanathan, Akshaya Prakash Sharma, Anurag Singh and Pulkit Singhal "Object Tracking Using Frame Differencing and Template Matching", Research Journal of Applied Sciences, Engineering and Technology , March 2012
- [7] Rahul Mishra, Mahesh K. Chouhan, Dr. Dhiiraj Nitawwre, "Multiple Object Tracking by Kernel Based Centroid Method for Improve Localization", IJ of Advanced Research in Computer Science and Software Engineering, Vol.2, No.7, pp. 137-140, 2012.
- [8] R. Venkatesh Babu , Patrick Perez and Patrick Bouthemy, " Robust tracking with motion estimation and local Kernel-based color modeling", Elsevier, Vol. 25, No. 8, pp. 1205-1216, 2007.
- [9] C. E. Perkins and E. M. Royer, "Ad-hoc On-Demand Distance Vector Routing," in Second IEEE Workshop on Mobile Computing Systems and Applications, 1999, pp. 90–100.
- [10] B. Li, Y. Liu, and G. Chu, "Improved AODV routing protocol for vehicular ad hoc networks," in Advanced Computer Theory and Engineering (ICACTE), 2010 3rd International Conference on, vol. 4, 2010, pp. V4–337–V4–340.
- [11] D. B. Johnson and D. A. Maltz, "Dynamic Source Routing in Ad Hoc Wireless Networks," in Mobile Computing, 1996, ch. 5.
- [12] M. Zhang and R. S. Wolff, "A Border Node Based Routing Protocol for Partially Connected Vehicular Ad Hoc Networks," Journal